



850B

LONG-TRACK DOZER



**SAE Net
Horsepower**

165 hp
(123 kW)

**Drive
System**

Dual-path
hydrostatic

**Operating
Weight SAE**

39,315 lb.
(17,855 kg)

Model shown may include options

ENGINE

John Deere engineered and manufactured 6-cylinder diesel engine. Replaceable wet-type cylinder liners help ensure superior heat dissipation, longer engine life. High-strength alloy heads include replaceable valve seat inserts. The forged steel, 7-main bearing crankshaft is statically and dynamically balanced for smooth operation. Cast aluminum pistons reduce rod bearing loads and provide vital heat transfer; pistons are sprayed with cooling oil for longer life.

Engine: John Deere 6466A

Rated power at 1800 rpm.....	165 SAE net hp (125 kW)
.....	175 SAE gross hp (131 kW)
Turbocharger	aftercooled
Cylinders	6
Displacement	466 cu. in. (7.638 L)
Fuel consumption, typical.....	4.5 to 6.4 gal./hr. (16.5 to 24.2 L/h)
Maximum net torque at 1200 rpm.....	578 lb.-ft. (784 Nm)
Lubrication.....	pressure system with full-flow filters
Air cleaner.....	dry type with restriction indicator
Electrical system.....	24-volt with 40-amp alternator
Cooling fan	blower

TRANSMISSION

Automatic, dual-path, hydrostatic drive provides infinitely variable speeds to 6.5 mph (10.5 km/h). The transmission's load sensing feature automatically adjusts speed and power to match changing load conditions. Each track is powered by a variable displacement piston pump and motor combination. The speed and direction of each track can be individually controlled.

TRAVEL SPEEDS

Forward and reverseinfinite to 6.5 mph (0 to 10.5 km/h)

FINAL DRIVES

Double-reduction, planetary final drives transfer torque loads over three gear sets instead of one. The final drives are mounted independently of the track frames to isolate them from shock loads for increased life and reliability.

BRAKES

Hydrostatic (dynamic) braking stops the crawler when the transmission control lever is moved to neutral. Wet, multi-disk parking brakes are automatically applied when the engine stops, or can be operator-applied by engaging the center brake pedal.

STEERING

Steering is done hydrostatically by varying track speed and/or direction. Depressing a pedal slows or varies the speed of the track, all the way to a stop if desired. Continuing to depress the pedal will cause the track to reverse for counterrotation. Hydrostatic steering eliminates the need for steering clutches and steering brakes, as well as the need for cross-steering when working on steep slopes.

HYDRAULICS

System	open center
Pressure.....	2250 psi (15 514 kPa)
Pump	variable
Flow at 1800 rpm.....	44 gpm (166 L/min.)

TRACKS

7-roller, 107-in. (2720 mm) track frame with front and rear track guides and sprocket guard. Dura-Trax™ undercarriage features deep-heat-treated, sealed and lubricated track links and through-hardened sealed and lubricated rollers for maximum wear resistance.

Crawler	24 in. (610 mm)
Shoes, each side	40
Ground contact area with 24-in. (610 mm) shoes	5136 sq. in. (33 135 cm ²)
Ground pressure.....	7.65 psi (52.7 kPa)
Ground clearance, minimum.....	16.4 in. (417 mm)
Length of track on ground.....	107 in. (2720 mm)
Track gauge, standard.....	74 in. (1880 mm)
Oscillation	11.5 in. (292 mm)
Carrier rollers each side	2
Adjustment.....	hydraulic

CAPACITIES

Fuel tank82 gal. (310.4 L)
Cooling system	9 gal. (34 L)
Crankcase	52 qt. (50.5 L)
Crankcase, including filter.....	34 qt. (32.2 L)
Splitter drive.....	1.5 gal. (5.7 L)
Final drive each: Inner compartment	5.5 gal. (20.8 L)
Outer compartment	3.5 gal. (13.2 L)
Hydraulic system	35 gal. (132.5 L)
Hydrostatic drives.....	40 gal. (151.4 L)

OPERATING WEIGHT

R50B Long-Track	39,315 lb. (17 833 kg)
-----------------------	------------------------

DIMENSIONS

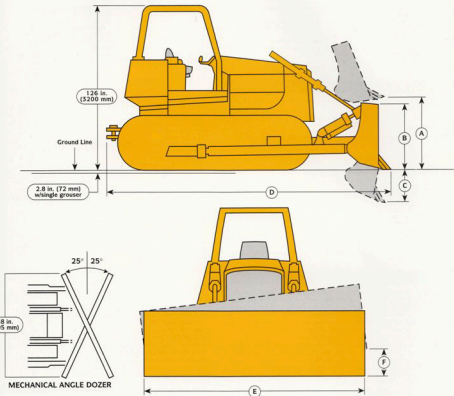

DOZER SPECIFICATIONS

Blade	A		B		C		D		E		F		Total	
	Capacity per SAE J1265	Blade Lift Height	Blade Height	Digging Depth	Overall Length (Tractor with Blade)	Overall Width* (Tractor with Blade)	Maximum Tilt	Weight	Operating Weight (Tractor with Blade)					
	yd ³ (m ³)	in. (mm)	in. (mm)	in. (mm)	in. (mm)	in. (mm)	in. (mm)	lb. (kg)	lb. (kg)					
Straight	3.89 2.97	42.0 1067	44.5 1130	20.6 525	214 5456	127 3226	15.0 381	4600 2086	39,515 17 833					
Semi U	5.40 4.13	43.0 1092	46.5 1181	20.2 513	222 5630	138 3500	15.0 381	5020 2277	39,700 17 995					
Angle	3.77 2.88	38.8 985	40.0 1016	18.7 475	214 5436	152 3860	13.25 336	5055 2284	39,715 18 015					

*Includes cupped end bit

HYDROSTATIC DRIVETRAIN

Dual-path hydrostatic drive provides many advantages over mechanical crawler drivetrains in the areas of machine performance and reliability.

Live power turns. Both tracks remain fully powered during turns. This affords greater maneuverability with larger loads and less ground disturbance. This feature also provides improved capability for working on soft ground, as well as the ability to counterbalance blade-corner loads when benching, ditching or backfilling.

Counterrotation. Separate control allows the two transmissions to be driven in opposite directions, permitting spot turns with excellent maneuverability. Quick blade position changes can be made.

Infinite speed selection. Infinitely variable ground speeds, from 0 to 6.5 mph (0–10.5 km/h), allow precise matching of machine speed to your application. Ground speed can be reduced without slowing engine rpm, so hydraulic power remains high and response time remains fast.

Automatic load sensing. As a load increases and engine rpm lessens, the transmission automatically reduces ground speed to

match load changes. This feature works at all throttle settings, providing full drawbar pull even at reduced engine speed.

Dynamic braking. Positive speed reduction is provided on slopes. When shifted to neutral, oil flow between the pump and motor is blocked. The crawler stops without use of the service brakes.

Efficiency. Overall, hydrostatic drive is more efficient in delivering horsepower to the tracks than systems that use torque converters. The greatest efficiency advantages are in the 1.5 to 3.5 mph (2.4 to 5.6 km/h) range, the main work speed range of a crawler dozer.

Simplicity. Hydrostatic drive design uses, on the average, 150 fewer parts than the design of an ordinary drive system. Fewer parts mean increased reliability. Some of our hydrostatic drive crawlers have accumulated more than 35,000 hours of use without any major transmission repairs.

FORESTRY APPLICATION

The 850B Long-Track Dozer can be equipped for forestry applications with the addition of limb risers and screens for the rollover protective structure.

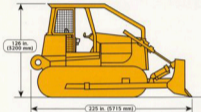

DRAWBAR PULL

Drawbar pull

At 1.2 mph (1.9 km/h)	35,500 lb. (149 kN)
At 2.0 mph (3.2 km/h)	21,000 lb. (95 kN)

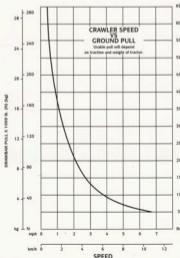



OPERATOR'S STATION

The 850BLT features a roomy, walk-through platform design. Controls are logically located, with transmission and throttle levers on your left and hydraulic levers on the right. Steering is done with easy-to-push pedals. Easy-to-read, color-coded, non-glare gauges are placed well within your forward field of vision.



EASY SERVICING

Convenient, exterior-mounted sight gauges provide a quick reading of hydrostatic and hydraulic fluid levels. The engine fluid and air filter restriction indicators are visible through doors on top of the hood. The dual-state, dry-type aspirated air cleaner nearly triples filter life, as well as eliminating daily servicing.

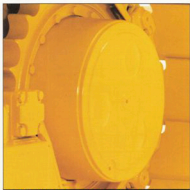

ISOLATED FINAL DRIVES

The double-reduction planetary final drives transfer torque loads over three gear sets instead of one. They're mounted independently of the track frames. This keeps shock loads away from the final drives and other vital drivetrain components. Modular design makes servicing easy.



COUNTERROTATION

The dual-path hydrostatic design lets you counter-rotate the tracks to turn the machine all the way around in the same spot—a big plus on small jobsites and in close quarters. There's less need to run in reverse, too, which helps the machine's undercarriage last longer.

ADDITIONAL STANDARD EQUIPMENT

Engine:
Air cleaner, dual-stage aspirated type
Air cleaner restriction indicator
Pre-cleaner
Fan guards
Engine coolant -34°F (-37°C)
Coolant recovery tank
Blower fan
Trash resistant radiator
Oil to water engine oil cooler
Power Train:
Dual-path hydrostatic transmission

Less clutch disconnect
Transmission neutral lock with starter safety switch
Transmission oil cooler
Hydraulics:
Two-spool hydraulic system
*O² ring face seal connectors
Lift cylinders
Electrical System:
Master electrical disconnect switch
Horn
Winch drive
Reverse warning alarm

Operator's Station:
Canopy (ROPS) with seat belt
Adjustable suspension seat
Adjustable armrests
Horn
Push button starting
Key switch
Hourmeter
Voltmeter
Interior-mounted rearview mirror

Overall Vehicle:
Heavy-duty bottom guards, front and rear

Lower engine side shields
Front pull hook
Front idler shields
Heavy-duty, hinged grille plate
Lockable toolbox
Muffler, self-draining, eliminating external rain cap
Tilt cylinder hose protection
Vandal protection

Tracks:
Dura-Trax sealed and lubricated chain
24-in. (610 mm) grouser shoes

OPTIONAL OR SPECIAL EQUIPMENT WITH WEIGHTS

(Add these weights to SAE standard equipment operating weights to obtain total operating weights.)

	lb.	kg		lb.	kg
Batteries (two 12-volt) cold-cranking capacity @ 0°F (-18°C) 925 amps, reserve capacity			Quick-drop valve	50	14
180 min. each	18	8	Lights, two front, one rear, halogen	7	3
Cab with pressurizer, heater and 50-amp alternator	400	182	Perforated hood	-10	-5
Air conditioner	109	49	Protection flams:		
Windshield wiper	3	1	Brush screens, heavy-duty, third post-type	275	125
Cold weather starting aid	4	2	Brush screens, regular-duty	72	33
Cupped end bits	10	4	Guards, lift cylinder	44	20
Dozers (included in total operating weight)			Guards, final-drive seal	58	17
6545 straight dozer	0	0	Guards, tank protection	650	295
Sims Li dozer	+385	+175	Limb risers	353	160
6540 Angle dozer	+400	+182	Perforated engine enclosure, heavy-duty	85	37
Disconnect clutch	20	9	Rear screen	50	25
*Drawbar, fixed	270	122	Roof extension	475	215
Engine coolant heater	2	1	Radiator sand shield	25	11
Fan, reversible	40	18	Rock guard, center-section	259	118
Fire extinguisher	6	3	Tracks:		
Hydraulics:			Dura-Trax sealed and lubricated chain w/plit master link		
Hydraulic lines to rear	4	2	20-in. (510 mm) grouser shoes	-624	-284
Hydraulic valve, third function	11	5	22-in. (560 mm) grouser shoes	-506	-139
Selector valve and lines to rear	14	6	Winch	2625	1190
Oil sampling test kit	2	1			

*Included in operating weight

THE JDAdvantEDGE

JDAdvantEdge is a wealth of support programs, parts systems and dealer resources, all designed to give you the edge. This package of special benefits is a major reason why John Deere offers the "best value" for your equipment dollar.

Best parts support - Twelve regional parts depots in North America and others around the world put parts support near your job no matter where in the world it is.

A computerized FLASH™ parts locating system linking these depots to dealerships can find out-of-stock parts in a hurry and get them into your hands fast. Usually within 24 hours.

Best service backup - Dealer service technicians are regularly schooled, at our modern facility in Davenport, Iowa, or by professionals in the field, to diagnose quickly and repair efficiently.

If they're stumped, a phone call to DTAC (Dealer Technical Assistance Center) puts them in touch with a staff of pros at the factory who help them find a solution quickly.

Best dealers - Your John Deere dealer is an important contributor to the JDAdvantEdge. He or she is committed to being the best equipment supplier you can work with.

This is a dollars-and-cents commitment in parts inventory, in service facilities, in field service trucks. It's a sweat-and-blood commitment in dedicated, skilled and highly trained and motivated personnel in each and every department at the dealership. But what sets John Deere dealers apart from all the rest is something more, a factor somewhat difficult to measure ... a caring attitude, and a sincere desire to be the best at meeting the needs of each individual customer.

John Deere Finance Plans - Whether you rent, lease or buy John Deere equipment, your dealer can explain the John Deere options available. One-stop options that let you free up operating capital, keep other lines of credit open. More solid benefits of the JDAdvantEdge.

Best protection - In addition to the new equipment warranty that meets or exceeds the competition, SECURE® extended coverage, an optional service product for John Deere equipment, is available for repair coverage after the warranty concludes. Full machine or power train coverage is available for a variety of time periods to meet your needs. Consult your dealer for availability and details.

Net engine power is with standard equipment including air cleaner, exhaust system, alternator, and cooling fan, at standard conditions per SAE J1349 and DIN 62708, using No. 2-D oil fuel at 35 API gravity. No derating is required up to 10,000 feet (3050 m) altitude. Gross power is without cooling fan.

Specifications and design subject to change without notice. Whenever applicable, specifications are in accordance with SAE standards. Except where otherwise noted, these specifications are based on a unit with rollover protective canopy, 24-in. (610 mm) grouser, engine enclosure, drawbar, front pull hook, full fuel tank, and 175-lb. (79 kg) operator and standard equipment.

