



YAMAHA

PARTS CATALOGUE

FS1'89 (3AV1)

SWEDEN

193AV-322E1



FOREWORD

This Parts Catalogue is related to the parts in use for the Yamaha FS1 '89 (3AV1).
When you are ordering replacement parts for the FS1 '89 (3AV1), refer to this Parts Catalogue and quote both part numbers and part names correctly.

1. Modifications or additions which have been made after issue of the Parts Catalogue will be announced in the Yamaha Parts News.

It is advisable that according to the Yamaha Parts News you make necessary corrections to the Parts Catalogue on hand to keep it up-to-date.

2. Abbreviations

The following abbreviations are used in this Parts Catalogue.

- U.R. Use size (thickness) and/or number as required.
U.N. Use as many as you need.
A.P. Alternate Parts
L.M. Local Made
F# Frame No. (Applicable machine No.)

3. The parts marked with (+) in the parts number column of this Catalogue are not supplied by Yamaha, those have to be found locally.
4. Parts, which are to be supplied in the form of assemblies, are listed with an indentation of one letter's space, and a dot (.) is put against the name of each part.

EXAMPLE CARBURETOR ASS'Y
.JET, pilot
.NOZZLE, main

5. Indication of No. of constituent parts for assembly

The numeral appearing to the right of each constituent part under the description indicates the quantity of such parts for each individual assembly unit.

EXAMPLE

Part No.	Description	Q'ty	Remarks
2F5-83310-60	FRONT FLASHER LIGHT ASS'Y	2	
115-83311-60	.BULB (6V-18W)	1	
1M1-83309-60	.REFLECTOR	1	

6. Initial Serial No. and Color Code

A	Frame Serial No.	3F1-244101 and following
B	Engine Serial No.	3F1-244101 and following



Color Code	Color Name	Abbreviate
33	YAMAHA BLACK	YB
G3	FRENCH BLUE	FBL
66	SUNSHINE RED	SR

7. Applicable colors of graphics are represented in the "Remarks" column by the letter(s) appropriately picked out of the full word(s) showing such colors.

EXAMPLE

Part No.	Description	Q'ty	Remarks
2N4-24110-00-X5	FUEL TANK COMP.	1	MAXIM RED
3J1-24240-10	.GRAPHIC, fuel tank set	1	for MXR

CONTENTS

ENGINE

Cylinder	B2
Crankshaft. Piston	B3
Intake	B4
Carburetor	B5 ~ B6
Exhaust	B7
Crankcase	B8
Crankcase Cover 1	B9
Starter	B10
Clutch	B11
Transmission	B12
Shift Cam. Fork	B13
Shift Shaft	B14

CHASSIS

Frame	B15
Fender	C2
Side Cover	C3
Rear Arm. Suspension	C4
Steering	C5
Front Fork	C6
Fuel Tank	C7
Seat	C8
Front Wheel	C9 ~ C10
Rear Wheel	C11 ~ C12
Steering Handle. Cable	C13
Stand. Footrest	C14
Generator	C15
Flasher Light	D2 ~ D3
Meter	D4

Headlight	D5
Taillight	D6
Handle Switch. Lever	D7
Electrical 1	D8
Electrical 2	D9

INDEX

Numerical Index	M1 ~ M3
-----------------------	---------

QTY	REF. NO.	DESCRIPTION	QTY	REMARKS
1	3F1-11111-00	HEAD, cylinder 1	1	
1	517-11181-00	GASKET, cylinder head 1	1	
1	94701-00039	PLUG, spark (NGK B6HS)	1	
1	3E8-11311-00	CYLINDER 1	1	
1	3AV-11351-00	GASKET, cylinder	1	
4	90116-06026	BOLT, stud	4	
4	95303-06600	NUT	4	
4	92901-06200	WASHER, plain	4	

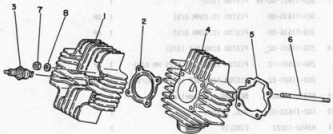
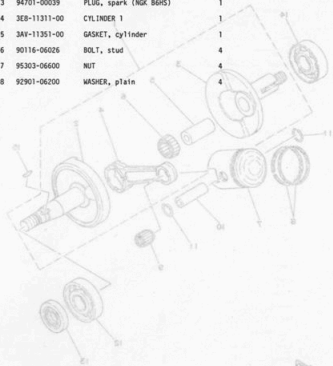

FIG. 1 CYLINDER

REF. NO.	PART NO.	DESCRIPTION	Q'TY	REMARKS
----------	----------	-------------	------	---------

1	3F1-11111-00	HEAD, cylinder 1	1	
2	517-11181-00	GASKET, cylinder head 1	1	
3	94701-00039	PLUG, spark (NGK B6HS)	1	
4	3E8-11311-00	CYLINDER 1	1	
5	3AV-11351-00	GASKET, cylinder	1	
6	90116-06026	BOLT, stud	4	
7	95303-06600	NUT	4	
8	92901-06200	WASHER, plain	4	



2RV310-7010



0505-01E1A2

FIG. 2 CRANKSHAFT, PISTON

REF. NO.	PART NO.	DESCRIPTION	Q'TY	REMARKS
1	3E8-11400-00	CRANKSHAFT ASSY	1	
2	3E8-11412-00	.CRANK 1	1	
3	3E8-11422-00	.CRANK 2	1	
4	3R1-11651-01	.ROD, connecting	1	
5	257-11681-00	.PIN, crank 1	1	
6	93310-418T0	.BEARING, cylindrical	1	
7	3E8-11631-00-96	PISTON (STD)	1	
	3E8-11635-00	PISTON (0.25MM O/S)	1	AP
	3E8-11636-00	PISTON (0.50MM O/S)	1	AP
8	260-11601-02	PISTON RING SET (STD)	1	
	260-11601-12	PISTON RING SET (0.25 MM O/S)	1	AP
	260-11601-22	PISTON RING SET (0.50 MM O/S)	1	AP
9	93310-11268	BEARING, cylindrical	1	
10	102-11633-02	PIN, piston	1	
11	93450-13022	CIRCLIP	2	
12	93306-20458	BEARING	1	
13	93102-20009	OIL SEAL	1	
14	93306-30302	BEARING (B6303C3)	1	
15	90280-03017	KEY, woodruff	1	

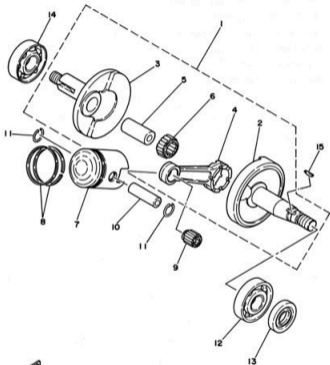

5A1310-2020

B3

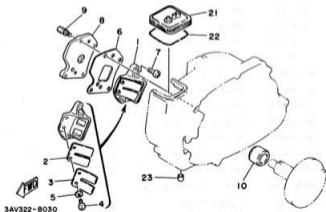
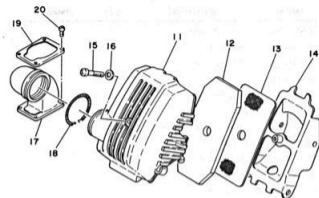

3AV322-8030

FIG. 3 INTAKE

REF. NO.	PART NO.	DESCRIPTION	Q'TY	REMARKS
1	378-13610-61	REED VALVE ASSY	1	
2	314-13613-01	REED, valve	1	
3	314-13616-01	STOPPER, reed valve	1	
4	98501-03008	SCREW, pan head	2	
5	92990-03100	WASHER, spring	2	
6	3AV-13621-00	GASKET, valve seat	1	
7	92501-06014	SCREW, pan head	2	
8	1X5-13505-00	JOINT, pump	1	
9	90109-06343	BOLT	4	
10	90387-17139	COLLAR	1	
11	5A3-14411-00	CASE, air cleaner 1	1	
12	3E8-14451-00	ELEMENT, air cleaner	1	
13	3E8-14473-00	GUIDE	1	
14	3E8-14498-00	STAY 1	1	
15	92503-06045	SCREW PAN HEAD	1	
16	92901-06600	WASHER, plate	1	
17	3E8-14453-00	JOINT, air cleaner 1	1	
18	90506-06106	SPRING, tension	1	
19	3E8-14417-00	COVER 1	1	
20	98580-04010	SCREW, pan head	4	
21	288-14481-02	CAP, carburetor	1	
22	90506-06095	SPRING, tension	1	
23	257-15433-00	CLEANER, drain	1	

FIG. 4 CARBURETOR

REF. NO.	PART NO.	DESCRIPTION	Q'TY	REMARKS
1	3F0-14101-00	CARBURETOR ASSY 1	1	
2	127-14141-14	.NOZZLE, main	1	
3	127-14143-23	.JET, main (#115)	1	UR STD
	127-14143-22	.JET, main (#110)	1	UR
	127-14143-24	.JET, main (#120)	1	UR
4	470-14185-00	.FLOAT	1	
5	260-14184-00	.GASKET, float chamber	1	
6	93220-08002	.O-RING	1	
7	92503-06018	.SCREW PAN HEAD	1	
8	363-14137-00	.CLIP	1	
9	260-14190-12	.NEEDLE VALVE ASSY	1	
10	127-W1412-00	.AIR SCREW SET	1	
11	260-14142-25	.JET, pilot (# 25)	1	
12	348-14116-03	.NEEDLE	1	
13	91401-12010	.PIN, cotter	1	
14	405-14114-00	.BAR, throttle	1	
15	283-14112-25	.VALVE, throttle 1	1	
16	127-14137-00	.CLIP	1	
17	287-14136-00	.SEAT, spring	1	
18	127-14131-00	.SPRING, throttle valve	1	
19	127-14133-00	.SPRING, throttle stop	1	
20	395-14121-00	.SCREW, throttle stop	1	
21	180-14158-01	.TOP, mixing chamber	1	
22	180-14168-00	.CAP, mixing chamber	1	
23	127-14161-00	.NUT, cable adjusting	1	
24	12G-14106-00	.CABLE ADJUST SCREW SET	1	
25	395-14171-00	.PLUNGER, starter	1	
26	156-14135-00	.SPRING, plunger	1	

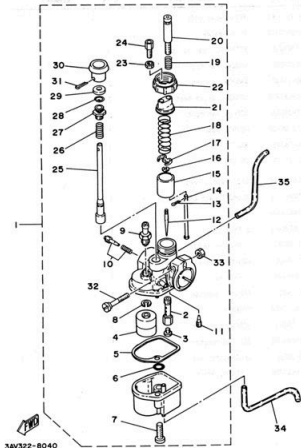

3AV322-8040

B5

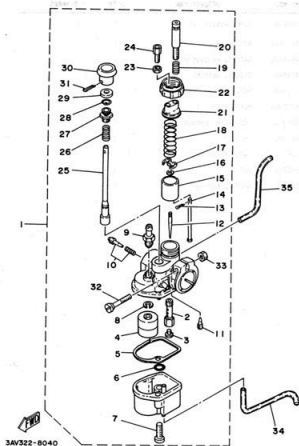
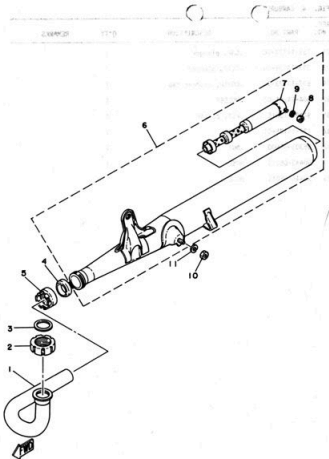

FIG. 4 CARBURE

REF. NO.	PART NO.	DESCRIPTION	Q'TY	REMARKS
27	152-14174-00	.CAP, plunger	1	
28	353-14138-00	.CLIP, plunger	1	
29	637-14173-00	.COVER, plunger cap	1	
30	304-14261-00	.HOLDER	1	
31	91401-16015	.PIN, cotter	1	
32	127-14125-01	.SCREW	1	
33	95303-05600	.NUT	1	
34	90445-05013	HOSE	1	
35	90445-05015	HOSE	1	



3F0322-2060

FIG. 5 EXHAUST

REF. NO.	PART NO.	DESCRIPTION	Q'TY	REMARKS
1	348-14611-00	PIPE, exhaust 1	1	
2	1L4-14612-00	NUT, ring	1	
3	3MT-14613-00	GASKET, exhaust pipe	1	
4	1J5-14714-00	GASKET, muffler	1	
5	1J5-14713-00	NUT, muffler joint	1	
6	1X5-14710-00	MUFFLER ASSY 1	1	
7	296-14753-02	.SILENCER, exhaust	1	
8	95303-05600	.NUT	1	
9	92901-05100	.WASHER, spring	1	
10	95303-08600	NUT	1	
11	92990-08100	WASHER, spring	1	

B7

QTY	UNIT	DESCRIPTION	IN	OUT
1	1	CRANKCASE 1	1	1
1	1	CRANKCASE 2	1	1
1	1	CRANKCASE 3	1	1
1	1	CRANKCASE 4	1	1
1	1	CRANKCASE 5	1	1
1	1	CRANKCASE 6	1	1
1	1	CRANKCASE 7	1	1
1	1	CRANKCASE 8	1	1
1	1	CRANKCASE 9	1	1
1	1	CRANKCASE 10	1	1
1	1	CRANKCASE 11	1	1
1	1	CRANKCASE 12	1	1
1	1	CRANKCASE 13	1	1
1	1	CRANKCASE 14	1	1
1	1	CRANKCASE 15	1	1
1	1	CRANKCASE 16	1	1
1	1	CRANKCASE 17	1	1
1	1	CRANKCASE 18	1	1

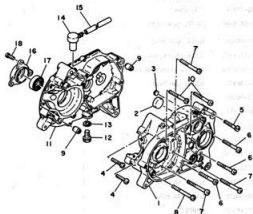
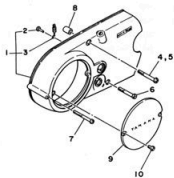
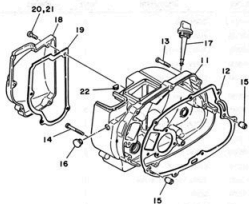

FIG. 6 CRANKCASE

REF. NO.	PART NO.	DESCRIPTION	Q'TY	REMARKS
1	257-15111-02	CRANKCASE 1	1	
2	90338-26136	PLUG	1	
3	90334-10006	PLUG, straight	1	
4	92501-06030	SCREW, pan head	2	
5	92503-06045	SCREW PAN HEAD	1	
6	92501-06050	SCREW, pan head	3	
7	92501-06060	SCREW, pan head	3	
8	92501-06065	SCREW, pan head	1	
9	99510-12016	PIN, dowel	2	
10	92501-06055	SCREW, pan head	2	
11	378-15121-60	CRANKCASE 2	1	
12	90340-12005	PLUG, straight screw	1	
13	90430-12207	GASKET	1	
14	583-15371-00	BREATHER	1	
15	90446-07009	HOSE	1	
16	378-15359-60	HOUSING, oil seal	1	
17	93103-25078	OIL SEAL	1	
18	92501-06014	SCREW, pan head	3	



 3AV322-8070

FIG. 7 CRANKCASE COVER 1

REF. NO.	PART NO.	DESCRIPTION	Q'TY	REMARKS
1	257-11541-01	CRANKCASE COVER ASSY 1	1	
2	132-16346-00	.HOOK, spring	1	
3	90506-07066	.SPRING, tension	1	
4	92503-06045	SCREW PAN HEAD	2	
5	92503-06045	SCREW PAN HEAD	1	
6	92501-06040	SCREW, pan head	1	
7	92501-06050	SCREW, pan head	1	
8	99530-10014	PIN, dowel	2	
9	164-15415-00	COVER, generator	1	
10	98501-04006	SCREW, pan head	2	
11	378-15421-60	COVER, crankcase 2	1	
12	3AV-15451-00	GASKET, crankcase cover 1	1	
13	92501-06030	SCREW, pan head	6	
14	92501-06040	SCREW, pan head	1	
15	99530-10014	PIN, dowel	2	
16	90480-12012	GROMMET	1	
17	315-15362-01	PLUG, oil level	1	
18	257-15413-00	COVER, carburetor	1	
19	3AV-15463-00	GASKET, carburetor cover 2	1	
20	92503-06018	SCREW PAN HEAD	1	
21	92503-06018	SCREW PAN HEAD	3	
22	129-15489-10	GROMMET	1	

B9

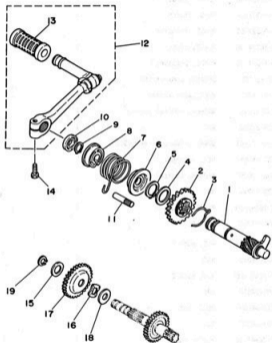

FIG. 8 STARTER

REF. NO.	PART NO.	DESCRIPTION	Q'TY	REMARKS
1	305-15660-04	KICK AXLE ASSY	1	
2	305-15641-00	GEAR, kick (26T)	1	
3	90468-26048	CLIP	1	
4	117-15644-00	SHIM	1	
5	93410-25017	CIRCLIP	1	
6	132-15664-01	GUIDE, spring	1	
7	90508-26136	SPRING, torsion	1	
8	132-15676-01	COVER, spring	1	
9	99009-15400	CIRCLIP	1	
10	93109-15001	OIL SEAL	1	
11	257-15668-00	STOPPER	1	
12	257-15620-01-91	KICK CRANK ASSY	1	UNI CHROME
13	156-15618-01	COVER, kick lever	1	
14	97011-06025	BOLT	1	
15	90201-13202	WASHER, plate	1	
16	90206-15021	WASHER, wave	1	
17	257-15651-01	GEAR, kick idle (26T)	1	
18	132-15653-00-10	WASHER	1	RADISH RED
19	99009-13400	CIRCLIP	1	



2RV310-7090

FIG. 9 CLUTCH

REF. NO.	PART NO.	DESCRIPTION	Q'TY	REMARKS
1	257-16150-03	PRIMARY DRIVEN GEAR COMP.	1	
2	122-16164-00	PLATE, thrust 2	1	
3	257-16371-01	BOSS, clutch	1	
4	598-16321-01	PLATE, friction	2	
5	598-16324-00	PLATE, clutch 1	2	
6	257-16351-00	PLATE, pressure 1	1	
7	90501-20122	SPRING, compression	4	
8	90119-05001	BOLT, with washer	4	
9	90208-12015	WASHER, conical spring	1	
10	90170-12060	NUT	1	
11	257-16111-01	GEAR, primary drive (19T)	1	
12	90282-05005	KEY, straight	1	
13	90208-12015	WASHER, conical spring	1	
14	90179-12244	NUT	1	
15	122-16164-00	PLATE, thrust 2	1	
16	90560-17150	SPACER	1	
17	137-16356-00	ROD, push 1	1	
18	93503-16010	BALL	1	
19	257-16357-00	ROD, push 2	1	
20	93501-04011	BALL	1	
21	90113-06009	BOLT, set	1	
22	95303-06700	NUT	1	
23	257-16341-00	SCREW, push	1	
24	257-16342-00	LEVER, push	1	
25	93102-04382	OIL SEAL	1	
26	93108-15001	OIL SEAL	1	
27	257-15417-01	COVER, cap	1	

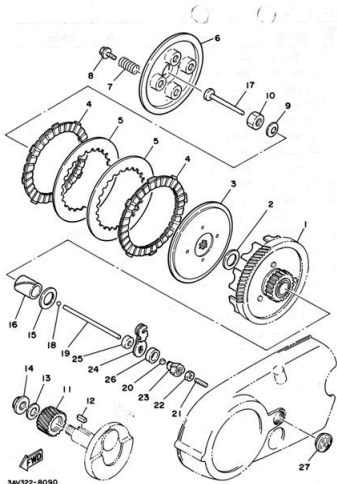

B11

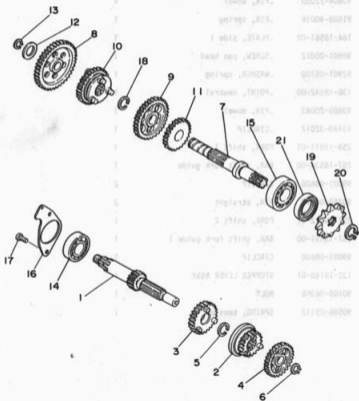
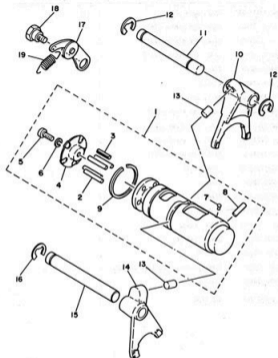

FIG. 10 TRANSMISSION

REF. NO.	PART NO.	DESCRIPTION	Q'TY	REMARKS
1	257-17411-01	AXLE, main (13T)	1	
2	257-17121-00	GEAR, 2nd pinion (18T)	1	
3	257-17131-01	GEAR, 3rd pinion (23T)	1	
4	257-17141-00	GEAR, 4th pinion (26T)	1	
5	93440-16089	CIRCLIP	1	
6	99009-13400	CIRCLIP	1	
7	3F0-17421-00	AXLE, drive	1	
8	257-17211-00	GEAR, 1st wheel (40T)	1	
9	257-17221-01	GEAR, 2nd wheel (34T)	1	
10	257-17231-00	GEAR, 3rd wheel (30T)	1	
11	3E8-17241-00	GEAR, 4th wheel (27T)	1	
12	257-17219-00	SHIM (0.6T)	1	
13	99009-13400	CIRCLIP	1	
14	93306-20333	BEARING	1	
15	93306-30301	BEARING (B6303)	1	
16	257-17471-01	PLATE, cover	1	
17	92501-06012	SCREW, pan head	2	
18	93440-16089	CIRCLIP	1	
19	93811-10001	SPROCKET, drive 10t (3471746100)	1	
20	99009-16400	CIRCLIP	1	
21	93102-17187	OIL SEAL	1	



5A1310-2130

FIG. 11 SHIFT CAM. FORK

REF. NO.	PART NO.	DESCRIPTION	Q'TY	REMARKS
1	257-18540-60	SHIFT CAM ASSY	1	
2	93604-22050	.PIN, dowel	4	
3	91609-40016	.PIN, spring	1	
4	164-18561-00	.PLATE, side 1	1	
5	90501-05012	.SCREW, pan head	1	
6	92901-05100	.WASHER, spring	1	
7	136-18542-00	.POINT, neutral	1	
8	93605-20043	.PIN, dowel	1	
9	93440-32017	.CIRCLIP	1	
10	259-18511-01	FORK, shift 1	1	
11	257-18534-00	BAR, shift fork guide	1	
12	99001-08600	CIRCLIP	2	
13	90250-06013	PIN, straight	2	
14	257-18512-01	FORK, shift 2	1	
15	257-18531-00	BAR, shift fork guide 1	1	
16	99001-08600	CIRCLIP	1	
17	132-18140-01	STOPPER LEVER ASSY	1	
18	90109-063F6	BOLT	1	
19	90506-09112	SPRING, tension	1	

B13

CHASSIS	TYP	DESCRIPTION	QTY	REMARKS
		SHIFT SHAFT ASSY	1	
		SCREW	1	
		SPRING, tension	1	
		SPRING, torsion	1	
		SCREW	1	
		NUT	1	
		PEDAL, shift	1	UNI CHROME
		COVER, shift pedal	1	
		BOLT	1	
		OIL SEAL (SD 12-22-5 HS)	1	
		WASHER, plate	1	
		CIRCLIP	1	

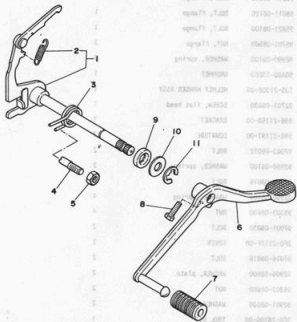
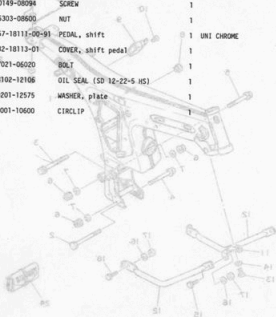

FIG. 12 SHIFT SHAFT

REF. NO.	PART NO.	DESCRIPTION	Q'TY	REMARKS
1	257-18101-01	SHIFT SHAFT ASSY	1	
2	90506-09009	.SPRING, tension	1	
3	90508-32207	SPRING, torsion	1	
4	90149-08094	SCREW	1	
5	95303-08600	NUT	1	
6	257-18111-00-91	PEDAL, shift	1	UNI CHROME
7	132-18113-01	COVER, shift pedal	1	
8	97021-06020	BOLT	1	
9	93102-12106	OIL SEAL (SD 12-22-5 HS)	1	
10	90201-12575	WASHER, plate	1	
11	99001-10600	CIRCLIP	1	



5A1310-2140

B14



0010-000000

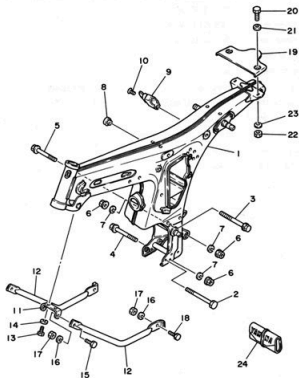

3AV1322-9130

FIG. 13 FRAME

REF. NO.	PART NO.	DESCRIPTION	Q'TY	REMARKS
1	473-21110-03-33	FRAME COMP.	1	YAMAHA BLACK
2	90101-08538	BOLT	1	
3	95811-08090	BOLT, flange	1	
4	95811-08120	BOLT, flange	1	
5	95821-08100	BOLT, flange	1	
6	95701-08500	NUT, flange	3	
7	92990-08100	WASHER, spring	3	
8	90480-13203	GRDMET	1	
9	1J5-21308-00	HELMET HANGER ASSY	1	
10	92701-06030	SCREW, flat head	1	
11	596-21158-00	BRACKET	1	
12	596-21191-00	DOWNTUBE	2	
13	97003-06012	BOLT	2	
14	92990-06100	WASHER, spring	2	
15	97313-08016	BOLT	2	
16	92990-08100	WASHER, spring	4	
17	95303-08600	NUT	4	
18	97001-08030	BOLT	2	
19	3F0-2117F-00	COVER	1	
20	97016-08016	BOLT	2	
21	92906-08600	WASHER, plate	2	
22	95303-08600	NUT	2	
23	92901-08600	WASHER, plate	2	
24	3F0-28100-00	TOOL KIT	1	

B15

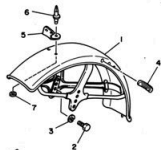
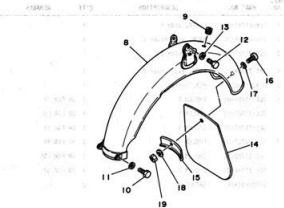

3AV322-8140

FIG. 14 FENDER

REF. NO.	PART NO.	DESCRIPTION	Q'TY	REMARKS
1	3F0-21510-00	FRONT FENDER COMP.	1	
2	97313-08012	BOLT	4	
3	92990-08100	WASHER, spring	4	
4	122-21517-00	PAD, cable	1	
5	3F0-85132-00	BRACKET, reflector 1	1	
6	90267-40031	RIVET, blind	2	
7	90201-044A2	WASHER, plate	2	
8	3AV-21610-00	REAR FENDER COMP.	1	
9	90480-13016	GROMMET	2	
10	97313-06016	BOLT	2	
11	92901-06600	WASHER, plate	2	
12	97313-08016	BOLT	2	
13	92990-08100	WASHER, spring	2	
14	526-21621-01	FLAP	1	
15	471-21623-00	BAND, flap	1	
16	92501-06014	SCREW, pan head	1	
17	92901-06600	WASHER, plate	1	
18	92990-06100	WASHER, spring	1	
19	95303-06600	NUT	1	

QTY	REF. NO.	PART NO.	DESCRIPTION	QTY
1	1	3E8-21711-00	COVER, side 1	1
1	2	1Y1-21714-00	KNOB, side cover 1	1
1	3	3E8-21721-00	COVER, side 2	1
1	4	1Y1-21724-00	KNOB, side cover 2	1
1	5	91401-50085	PIN, cotter	1
1	6	3EE-21781-00	EMBLEM 1	1 UR FOR YB
1		3EE-21781-10	EMBLEM 1	1 UR FOR FBL
1		3EE-21781-20	EMBLEM 1	1 UR FOR SR
1	7	3EE-21782-00	EMBLEM 2	1 UR FOR YB
1		3EE-21782-10	EMBLEM 2	1 UR FOR FBL
1		3EE-21782-20	EMBLEM 2	1 UR FOR SR
2	8	90480-01401	GROMMET	2

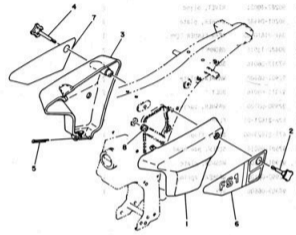
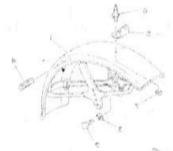

FIG. 15 SIDE COVER

REF. NO.	PART NO.	DESCRIPTION	Q'TY	REMARKS
1	3E8-21711-00	COVER, side 1	1	
2	1Y1-21714-00	KNOB, side cover 1	1	
3	3E8-21721-00	COVER, side 2	1	
4	1Y1-21724-00	KNOB, side cover 2	1	
5	91401-50085	PIN, cotter	1	
6	3EE-21781-00	EMBLEM 1	1	UR FOR YB
	3EE-21781-10	EMBLEM 1	1	UR FOR FBL
	3EE-21781-20	EMBLEM 1	1	UR FOR SR
7	3EE-21782-00	EMBLEM 2	1	UR FOR YB
	3EE-21782-10	EMBLEM 2	1	UR FOR FBL
	3EE-21782-20	EMBLEM 2	1	UR FOR SR
8	90480-01401	GROMMET	2	



 YAMAHA
NEESSI-8150



 YAMAHA
GIND-SCENGE

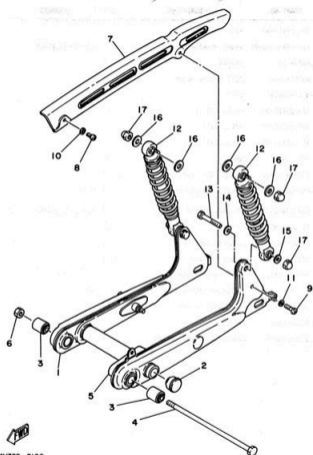

FIG. 16 REAR ARM SUSPENSION

REF. NO.	PART NO.	DESCRIPTION	Q'TY	REMARKS
1	1X6-22110-00-33	REAR ARM COMP.	1	YAMAHA BLACK
2	180-22117-00	CAP	2	
3	102-22123-00	BUSH 1	2	
4	40X-22141-00	SHAFT, pivot	1	
5	296-22151-01	SEAL, guard	1	
6	90185-10060	NUT, self-locking	1	
7	260-22311-00-35	CASE, chain	1	SILVER
8	98501-05008	SCREW, pan head	1	
9	98501-05020	SCREW, pan head	1	
10	92901-05600	WASHER, plate	1	
11	92901-05600	WASHER, plate	1	
12	3W3-22210-10	SHOCK ABSORBER ASSY, rear	2	UR CHAPPY RED
	3W3-22210-20	SHOCK ABSORBER ASSY, rear	2	UR COMPETITION YELLOW
13	90101-10255	BOLT	2	
14	90201-10437	WASHER, plate	2	
15	92901-10200	WASHER, plain	2	
16	90201-10437	WASHER, plate	4	
17	90176-10013	NUT, crown	4	

3AV322-8160

C4

FIG. 17 STEERING

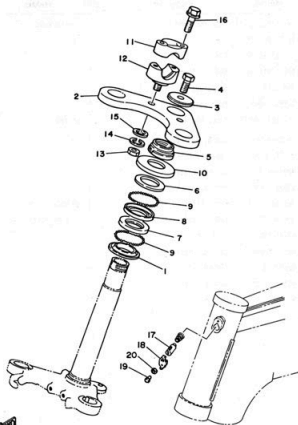

REF. NO.	PART NO.	DESCRIPTION	Q'TY	REMARKS
1	156-23411-00	RACE, ball 1	1	
2	185-23435-00-98	CROWN, handle	1	LOW GLOSS BLACK
3	90209-10021	WASHER	1	
4	90105-10006	BOLT, washer based	1	
5	90179-25051	NUT	1	
6	183-23411-00	RACE, ball 1	1	
7	156-23412-00	RACE, ball 2	1	
8	183-23412-00	RACE, ball 2	1	
9	93501-04011	BALL	38	
10	136-23415-00	COVER, ball race 1	1	
11	462-23441-00	HOLDER, handle upper	2	BLACK
12	462-23442-00-98	HOLDER, handle lower	2	LOW GLOSS BLACK
13	95303-10600	NUT	2	
14	92901-10100	WASHER, spring	2	
15	92990-10600	WASHER, plate	2	
16	90119-06017	BOLT, with washer	4	
17	*	STEERING LOCK ASSY	1	LM
18	134-23484-10	CAP, handle lock	1	
19	90269-04003	RIVET	1	
20	90208-04029	WASHER, conical spring	1	

3F0322-2180

C5

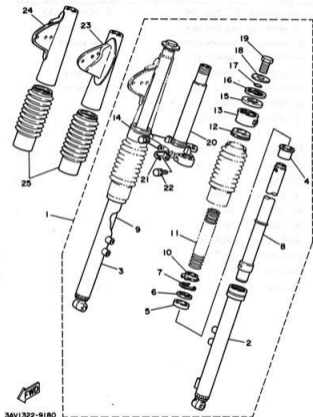

3AV1322-91B0

FIG. 18 FRONT F

REF. NO.	PART NO.	DESCRIPTION	Q'TY	REMARKS
1	3AV-23101-10	FRONT FORK ASSY	1	CHAPPY RED
2	3W3-23126-00-35	.TUBE, outer 1	1	SILVER
3	3W3-23136-00-35	.TUBE, outer 2	1	SILVER
4	367-23125-60	.METAL, slide 1	2	
5	1TB-23145-00	.OIL SEAL	2	
6	367-23146-60	.WASHER, oil seal	2	
7	1TB-23156-00	.CLIP, oil seal	2	
8	3E9-23124-00	.TUBE, inner 1	1	
9	3E9-23134-00	.TUBE, inner 2	1	
10	3W3-23117-00	.GUIDE, spring	2	
11	481-23141-01	.SPRING, front fork	2	
12	209-23142-40	.SEAT, spring upper	2	
13	353-23122-91	.COVER, outer 1	1	
14	353-23132-91	.COVER, outer 2	1	
15	207-23163-00	.GASKET	2	
16	201-23116-00	.GUIDE, cover lower	2	
17	307-23114-00	.GASKET	2	
18	207-23112-00	.WASHER, cap	2	
19	395-23111-00	.BOLT, cap	2	
20	1Y2-23340-30-33	.UNDER BRACKET COMP.	1	YAMAHA BLACK
21	260-23318-40	.HOLDER, cable 1	1	
22	1M3-23346-00	.BOLT 1	2	
23	2RV-23121-00-33	COVER, upper 1	1	YAMAHA BLACK
24	2RV-23131-00-33	COVER, upper 2	1	YAMAHA BLACK
25	3E9-23191-10	BOOT	2	UR CHAPPY RED
	3E9-23191-20	BOOT	2	UR COMPETITION YELLOW

C6

FIG. 19 FUEL TANK

REF. NO.	PART NO.	DESCRIPTION	Q'TY	REMARKS
1	3E8-24110-01-M1	FUEL TANK COMP.	1	UR YAMAHA BLACK
	3E8-24110-01-M2	FUEL TANK COMP.	1	UR FRENCH BLUE
	3E8-24110-01-M3	FUEL TANK COMP.	1	UR SUNSHINE RED
2	3EE-24240-01	.GRAPHIC SET	1	UR FOR YB
	3EE-24240-11	.GRAPHIC SET	1	UR FOR FBL
	3EE-24240-21	.GRAPHIC SET	1	UR FOR SR
3	122-24181-00	DAMPER, locating 1	2	
4	3E8-24185-00	DAMPER, locating 5	1	
5	122-24610-01	CAP ASSY	1	
6	122-24612-01	.GASKET, cap	1	
7	367-24500-04	FUEL COCK ASSY 1	1	
8	102-24522-01	.GASKET	1	
9	122-24532-00	.GASKET	1	
10	603-24531-01	.NUT	1	
11	355-24523-00	.VALVE	1	
12	355-24518-01	.SPRING, lever	1	
13	95303-05600	.NUT	1	
14	90445-09353	HOSE	1	
15	90467-08003	CLIP	2	

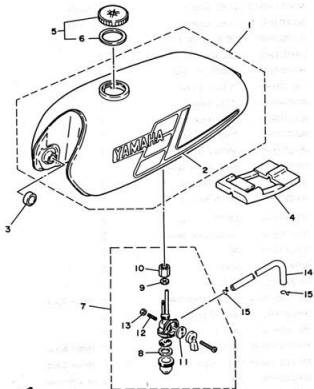

3AU1310-9210

C7

FIG. 20 SEAT

REF. NO.	PART NO.	DESCRIPTION	Q'TY	REMARKS
1	3F0-M2471-00	SINGLE SEAT ASSY	1	
2	3F0-24711-00	COVER, single seat	1	
3	214-24724-00	DAMPER, seat	2	
4	3E8-24756-00	COVER, tail	1	UR YAMAHA BLACK
	3E8-24756-30	COVER, tail	1	UR FRENCH BLUE
	3E8-24756-60	COVER, tail	1	UR SUN-SHINE RED
5	95303-05600	NUT	4	
6	92990-05100	WASHER, spring	4	
7	92990-05200	WASHER, plain	4	
8	97001-08018	BOLT	2	
9	92901-08200	WASHER, plain	2	
10	3W3-24840-00	CARRIER ASSY	1	

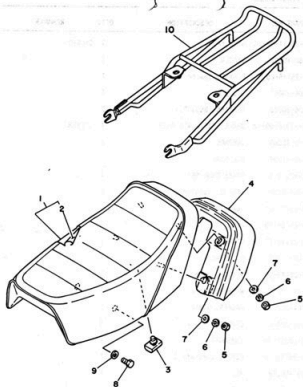

3F0322-2210

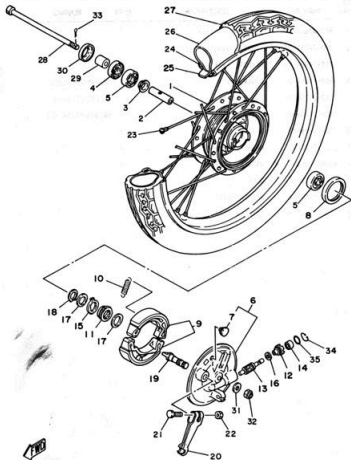

3A/322-10

FIG. 21 FRONT WHEEL

REF. NO.	PART NO.	DESCRIPTION	Q'TY	REMARKS
1	517-25111-00-Y8	HUB, front	1	SILVER
2	90560-10292	SPACER	1	
3	195-25115-00	FLANGE, spacer 1	1	
4	93106-20001	OIL SEAL	1	
5	93306-30003	BEARING (B6300Z)	2	
6	1K8-25016-00-Y8	BRAKE SHOE PLATE ASSY	1	SILVER
7	90480-10068	GROMMET	1	
8	93105-47007	OIL SEAL	1	
9	2JL-W2536-01	BRAKE SHOE SET	1	
10	90506-18288	SPRING, tension	2	
11	296-25135-00	GEAR, drive	1	
12	109-25136-00	BUSH	1	
13	296-25138-00	GEAR, meter	1	
14	93104-07003	OIL SEAL	1	
15	183-25149-00	CLUTCH, meter	1	
16	90201-07076	WASHER, plate	1	
17	90201-20269	WASHER, plate	2	
18	99009-20400	CIRCLIP	1	
19	316-25351-00	CAMSHAFT	1	
20	538-25155-00	LEVER, camshaft 1	1	
21	90101-06278	BOLT	1	
22	95303-06600	NUT	1	
23	109-25104-10	SPOKE SET, front	1	
24	94412-17002	RIM (1.20-17)	1	
25	94332-17112	BAND, rim (3.25-17)	1	INOUE
26	94225-17082	TUBE (2.50-17)	1	YOKOHAMA
27	94125-17259	TIRE (2.50-17)	1	YOKOHAMA
28	353-25181-03	AXLE, wheel	1	

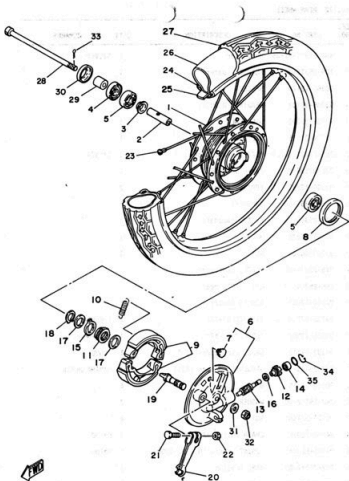
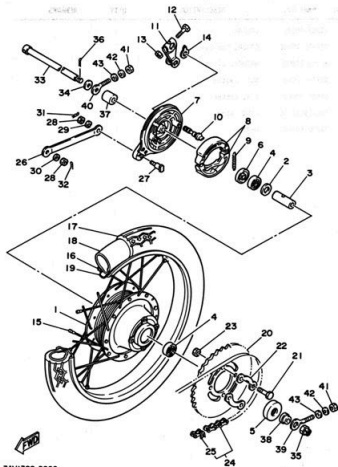

FIG. 21 FRONT VIEW

REF. NO.	PART NO.	DESCRIPTION	Q'TY	REMARKS
29	90387-10277	COLLAR	1	
30	322-25118-00	COVER, hub dust	1	
31	92990-10600	WASHER, plate	1	
32	90171-10004	NUT, castle	1	
33	91401-20020	PIN, cotter	1	
34	102-25137-00	RING, stop	1	
35	93210-14104	O-RING	1	



3AV1322-9220

FIG. 22 REAR WHEEL

REF. NO.	PART NO.	DESCRIPTION	Q'TY	REMARKS
1	462-25311-01-35	HUB, rear	1	SILVER
2	109-25315-00	FLANGE, spacer	1	
3	90560-12170	SPACER	1	
4	93306-30101	BEARING (B6301)	2	
5	93106-20002	OIL SEAL	1	
6	93104-21016	OIL SEAL	1	
7	355-25321-10-35	PLATE, brake shoe	1	SILVER
8	2JL-M2536-01	BRAKE SHOE SET	1	
9	90506-18288	SPRING, tenston	2	
10	3Y6-25351-00	CAMSHAFT	1	
11	1T9-25355-00	LEVER, camshaft	1	
12	90101-06278	BOLT	1	
13	95303-06600	NUT	1	
14	3Y6-2533A-01	PLATE, indicator	1	
15	296-25304-10	SPOKE SET, rear	1	
16	94414-17003	RIM (1.40-17)	1	
17	94125-17259	TIRE (2.50-17)	1	YOKOHAMA
18	94225-17082	TUBE (2.50-17)	1	YOKOHAMA
19	94332-17112	BAND, rim (3.25-17)	1	INOUE
20	288-25445-10-33	SPROCKET, driven (45T)	1	YAMAHA BLACK
21	90109-08319	BOLT	4	
22	2A3-25412-00	WASHER	2	
23	90170-08158	NUT	4	
24	94580-52098	CHAIN (D.I.D.420M 98L)	1	DAIDO
25	94680-52001	JOINT, chain (D.I.D.-420M)	1	DAIDO
26	102-25371-00	BAR, tension	1	
27	90109-08183	BOLT	1	
28	95303-08700	NUT	2	

C11

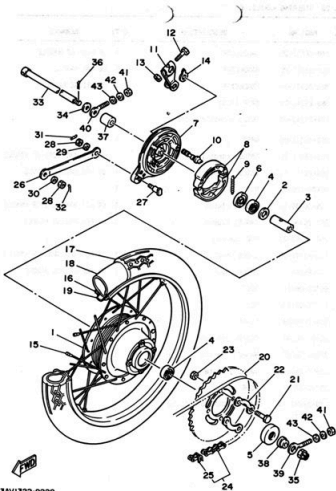
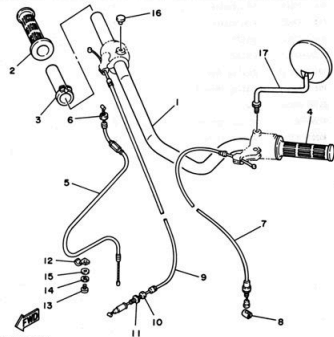
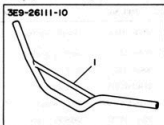
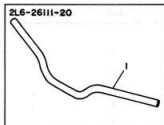

FIG. 22 REAR WHEEL

REF. NO.	PART NO.	DESCRIPTION	Q'TY	REMARKS
29	92990-08100	WASHER, spring	1	
30	92901-08200	WASHER, plain	1	
31	90468-10050	CLIP	1	
32	91401-20015	PIN, cotter	1	
33	353-25381-00	AXLE, wheel	1	
34	90201-122A7	WASHER, plate	1	
35	90171-10004	NUT, castle	1	
36	91401-20020	PIN, cotter	1	
37	90387-12412	COLLAR	1	
38	90387-127E0	COLLAR	1	
39	100-25388-00	PULLER, chain 1	1	
40	102-25389-00	PULLER, chain 2	1	
41	95303-06600	NUT	2	
42	92990-06100	WASHER, spring	2	
43	90201-061A5	WASHER, plate	2	

3AV1322-9220

C12



3AV322-0231

FIG. 23 STEERING HANDLE. C13

REF. NO.	PART NO.	DESCRIPTION	Q'TY	REMARKS
1	1Y0-26111-00	HANDLEBAR	1	UR SEMI-UP HANDLE
	2L6-26111-20	HANDLEBAR	1	UR BAR HANDLE
	3E9-26111-10	HANDLEBAR	1	UR BRIDGE HANDLE
2	353-26242-00	GRIP (R.H)	1	
3	1V1-26243-00	TUBE, throttle guide	1	
4	353-26241-00	GRIP	1	
5	1X3-26311-00	CABLE, throttle 1	1	UR FOR BAR/SEMI-UP HANDLE
	394-26311-10	CABLE, throttle 1	1	UR FOR BRIDGE HANDLE
6	90170-10038	NUT	1	
7	355-26335-10	CABLE, clutch	1	UR FOR BAR/SEMI-UP HANDLE
	3F0-26335-10	CABLE, clutch	1	UR FOR BRIDGE HANDLE
8	164-26363-00	END, cable	1	
9	1Y0-26341-00	CABLE, brake	1	UR FOR BAR/SEMI-UP HANDLE
	132-26341-10	CABLE, brake	1	UR FOR BRIDGE HANDLE
10	90123-06011	BOLT	1	
11	90179-06143	NUT	1	
12	90462-06009	CLAMP	1	
13	92501-06008	SCREW, pan head	1	
14	92990-06100	WASHER, spring	1	
15	92901-06600	WASHER, plate	1	
16	90338-07011	PLUG	1	
17	1Y0-26290-10	BACK MIRROR ASSY (L.H)	1	

C13

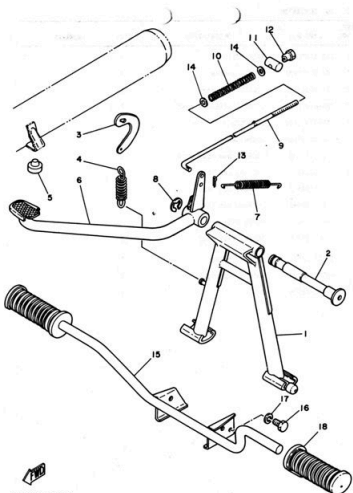
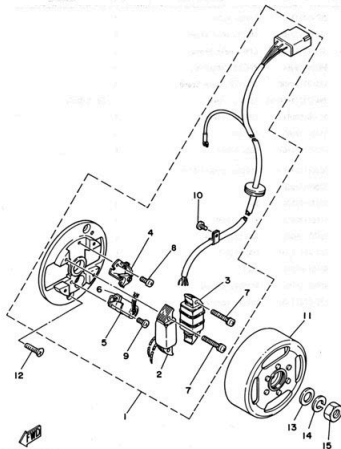

FIG. 24 STAND, REST

REF. NO.	PART NO.	DESCRIPTION	Q'TY	REMARKS
1	207-27111-00	STAND, main	1	
2	122-27112-00	SHAFT, main stand	1	
3	109-27115-00	LINK, main stand	1	
4	90506-29054	SPRING, tension	1	
5	116-27114-00	STOPPER, main stand	1	
6	394-27211-00-91	PEDAL, brake	1	UNI CHROME
7	90506-20041	SPRING, tension	1	
8	93430-12008	CIRCLIP	1	
9	180-27231-01	ROD, brake	1	
10	90501-10245	SPRING, compression	1	
11	90249-12008	PIN	1	
12	90179-06176	NUT	1	
13	91401-20015	PIN, cotter	1	
14	92901-06600	WASHER, plate	2	
15	260-27411-00	FOOTREST 1	1	
16	90101-08246	BOLT	1	
17	92990-08100	WASHER, spring	1	
18	122-27413-00	COVER, footrest	2	

3FO322-2250

C14



3AV322-8250

FIG. 25 GENERATOR

REF. NO.	PART NO.	DESCRIPTION	Q'TY	REMARKS
1	1X6-81310-20	BASE ASSY	1	
2	207-81312-21	.COIL, source	1	
3	1X6-81313-20	.COIL, lighting 1	1	
4	2A6-81321-20	.CONTACT BREAKER ASSY	1	
5	1K8-81325-20	.CONDENSER 1	1	
6	116-81331-20	.LUBRICATOR	1	
7	97602-04125	.SCREW, pan head with washer	4	
8	110-81346-21	.SCREW, pan head	1	
9	110-81346-21	.SCREW, pan head	1	
10	110-81345-21	.SCREW, pan head	1	
11	1X6-81350-20	ROTOR ASSY	1	
12	98701-05016	SCREW, flat head	2	
13	90201-12535	WASHER, plate	1	
14	92901-12100	WASHER, spring	1	
15	90170-12175	NUT	1	

C15

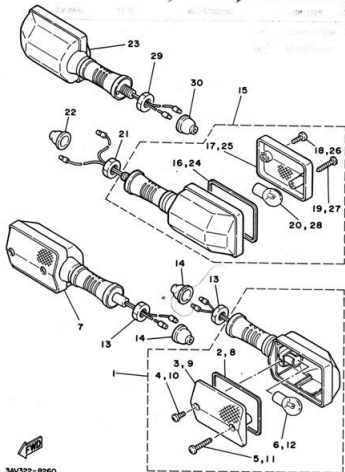

3AV322-8260

FIG. 26 FLASHER LIGHT

REF. NO.	PART NO.	DESCRIPTION	Q'TY	REMARKS
1	3AV-83310-00	FRONT FLASHER LIGHT ASSY 1	1	
2	5Y1-83313-00	.GASKET, flasher lens	1	
3	34N-83312-00	.LENS, flasher	1	
4	98511-04012	.SCREW, pan head	1	
5	97702-40630	.SCREW, tapping	1	
6	152-83311-10	.BULB (6V-10W)	1	
7	3AV-83320-00	FRONT FLASHER LIGHT ASSY 2	1	
8	5Y1-83313-00	.GASKET, flasher lens	1	
9	34N-83312-00	.LENS, flasher	1	
10	98511-04012	.SCREW, pan head	1	
11	97702-40630	.SCREW, tapping	1	
12	152-83311-10	.BULB (6V-10W)	1	
13	95302-12600	NUT	2	
14	10V-83365-00	CAP	2	
15	3AV-83330-00	REAR FLASHER LIGHT ASSY 1	1	
16	5Y1-83313-00	.GASKET, flasher lens	1	
17	34N-83332-00	.LENS, flasher	1	
18	98511-04012	.SCREW, pan head	1	
19	97702-40630	.SCREW, tapping	1	
20	152-83311-10	.BULB (6V-10W)	1	
21	95302-12600	NUT	1	
22	10V-83365-00	CAP	1	
23	3AV-83340-00	REAR FLASHER LIGHT ASSY 2	1	
24	5Y1-83313-00	.GASKET, flasher lens	1	
25	34N-83332-00	.LENS, flasher	1	
26	98511-04012	.SCREW, pan head	1	
27	97702-40630	.SCREW, tapping	1	
28	152-83311-10	.BULB (6V-10W)	1	

D2

FIG. 26 FLASHER LIGHT

REF. NO.	PART NO.	DESCRIPTION	Q'TY	REMARKS
29	95302-12600	NUT	1	
30	10V-83365-00	CAP	1	

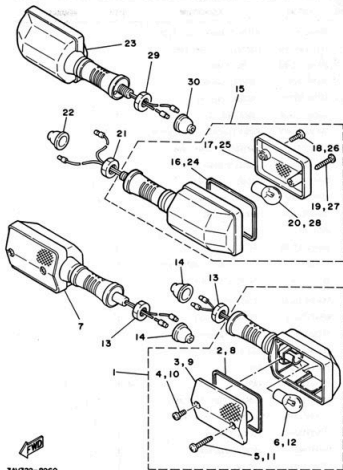

3AV322-8260

D3

FIG. 27 METER

REF. NO.	PART NO.	DESCRIPTION	Q'TY	REMARKS
1	3F4-83510-F0	SPEEDOMETER ASSY	1	KM/H
2	4A7-83520-00	.SOCKET CORD ASSY	1	
3	122-83516-10	.BULB (6V-3W)	2	
4	3F2-83519-00	BRACKET, meter	1	
5	1M3-83513-00	DAMPER	2	
6	355-83526-00	DAMPER 2	2	
7	355-83522-00	COLLAR	2	
8	90201-06412	WASHER, plate	2	
9	95303-06600	NUT	2	
10	241-83550-01	SPEEDOMETER CABLE ASSY	1	

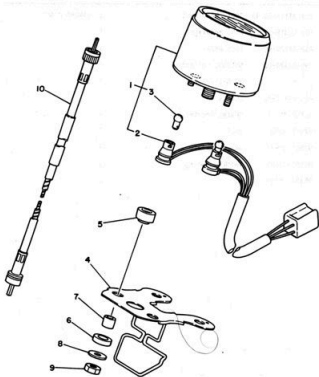

5A4322-2290

D4

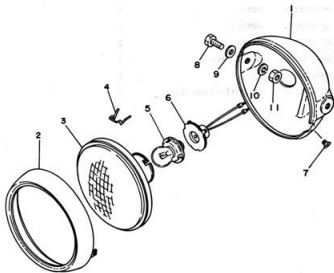

FIG. 28 HEADLIGHT

REF. NO.	PART NO.	DESCRIPTION	Q'TY	REMARKS
1	354-84111-00-33	BODY, headlight	1	YAMAHA BLACK
2	195-84315-01	RIM, headlight	1	
3	468-84120-40	LENS ASSY	1	
4	195-84324-00	SPRING, reflector	3	
5	*	BULB (6Y-15W)	1	LM
6	468-84112-40	SOCKET	1	
7	90152-05005	SCREW, countersunk	1	
8	97001-08020	BOLT	2	
9	92901-08600	WASHER, plate	2	
10	92990-08100	WASHER, spring	2	
11	95303-08700	NUT	2	



3A/322-8290

Ds

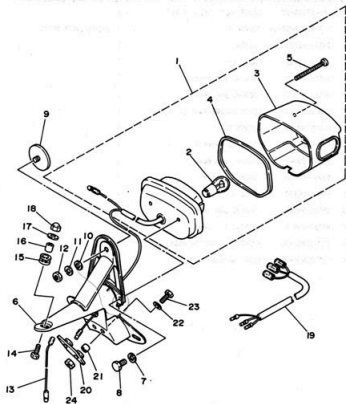



 2RV310-7310

FIG. 29 TAILLIGHT

REF. NO.	PART NO.	DESCRIPTION	Q'TY	REMARKS
1	2RV-84510-E0	TAILLIGHT UNIT ASSY	1	
2	1M8-84514-41	.BULB (6V-21/5W)	1	
3	543-84521-41	.LENS, taillight	1	
4	296-84523-00	.GASKET, lens	1	
5	127-84524-30	.SCREW, lens fitting	2	
6	2RV-84551-00-35	BRACKET, licence	1	SILVER
7	92990-06100	WASHER, spring	2	
8	97013-06012	BOLT	2	
9	449-85131-02	REFLECTOR, rear 1	1	
10	92990-05200	WASHER, plain	1	
11	92990-05100	WASHER, spring	1	
12	95303-05600	NUT	1	
13	2RV-84556-00	WIRE, earth lead	1	
14	97001-06020	BOLT	1	
15	90480-14023	GROMMET	1	
16	90387-07390	COLLAR	1	
17	90209-06095	WASHER	1	
18	95303-06800	NUT, crown	1	
19	3AV-84517-10	CORD, taillight	1	
20	214-84553-01	DAMPER	1	
21	90387-06241	COLLAR	2	
22	90201-06059	WASHER, plate	2	
23	97001-06020	BOLT	2	
24	95303-06600	NUT	2	

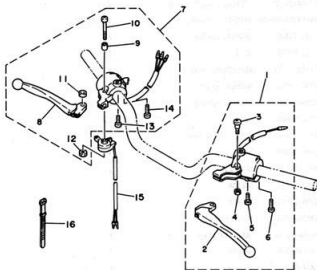
FIG. 30 HANDLE SWITCH, LEV



REF. NO.	PART NO.	DESCRIPTION	Q'TY	REMARKS
1	3AV-82910-00	LEVER HOLDER ASSY (LEFT)	1	
2	137-83912-02-38	.LEVER 1	1	CLEAR (WITH BUFF)
3	90149-05120	.SCREW	1	
4	95601-05100	.NUT, u	1	
5	98501-05018	.SCREW, pan head	1	
6	90157-05027	.SCREW, pan head	2	
7	3F0-82920-30	LEVER HOLDER ASSY (RIGHT)	1	
8	2N3-83922-00	.LEVER 2	1	
9	137-83913-01	.COLLAR, lever 1	1	
10	98501-05046	.SCREW, pan head	1	
11	92990-05200	.WASHER, plain	1	
12	95601-05100	.NUT, u	1	
13	98501-05018	.SCREW, pan head	1	
14	90157-05027	.SCREW, pan head	2	
15	232-83980-30	FRONT STOP SWITCH ASSY	1	
16	437-83936-00	BAND, switch cord	2	

3AV/322-8300

D7

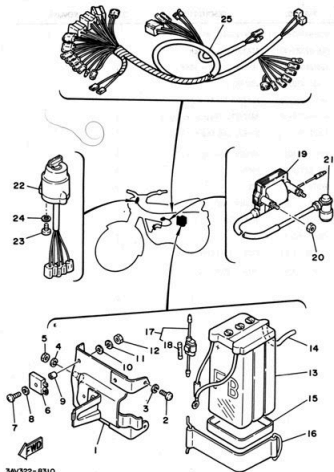

3AV322-8310

FIG. 31 ELECTRICAL

REF. NO.	PART NO.	DESCRIPTION	Q'TY	REMARKS
1	1Y1-81975-00	PLATE, rectifier fitting	1	
2	92501-06012	SCREW, pan head	2	
3	92990-06100	WASHER, spring	2	
4	92990-06100	WASHER, spring	1	
5	95303-06600	NUT	1	
6	353-81970-63	RECTIFIER ASSY	1	STANLEY
7	98503-05025	SCREW, pan head	1	
8	92901-05600	WASHER, plate	1	
9	90307-066M3	COLLAR	1	
10	92990-05200	WASHER, plain	1	
11	92901-05100	WASHER, spring	1	
12	95303-05600	NUT	1	
13	104-82110-29	BATTERY ASSY (6N4A-4D)	1	FURUKAMA
14	90445-08171	HOSE	1	
15	104-82122-00	SEAT, battery	1	
16	1Y1-82131-00	BAND, battery	1	
17	353-82150-00	FUSE HOLDER ASSY	1	
18	116-82151-00	.FUSE (10A)	1	
19	355-82310-40	IGNITION COIL ASSY	1	
20	95303-06600	NUT	2	
21	56J-82370-00	PLUG CAP ASSY	1	
22	3F6-82510-20	MAIN SWITCH ASSY	1	
23	98501-05012	SCREW, pan head	2	
24	92901-05100	WASHER, spring	2	
25	3AV-82590-00	WIRE HARNESS ASSY	1	

D8

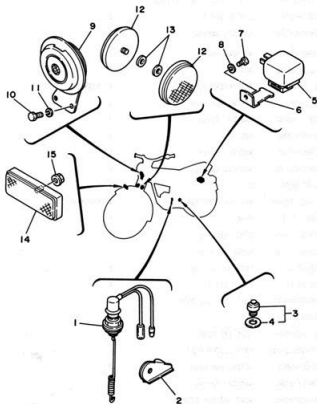

3A/322-8320

FIG. 32 ELECTRICAL 2

REF. NO.	PART NO.	DESCRIPTION	Q'TY	REMARKS
1	205-82530-02	STOP SWITCH ASSY	1	
2	205-82539-00	STAY, stop switch	1	
3	136-82540-00	NEUTRAL SWITCH ASSY	1	
4	90430-11034	.GASKET	1	
5	38A-83350-10	FLASHER RELAY ASSY	1	
6	474-83352-00	BRACKET, flasher relay 1	1	
7	92501-06012	SCREW, pan head	1	
8	92990-06100	WASHER, spring	1	
9	2A7-83371-10	HORN	1	
10	97011-06010	BOLT	2	
11	92990-06100	WASHER, spring	2	
12	355-85111-01	REFLECTOR, front 1	2	
13	90430-06012	GASKET	2	
14	34U-85110-00	FRONT REFLECTOR ASSY	1	
15	95701-05500	NUT, flange	1	

D9

INDEX

NUMERICAL INDEX

PART NO.	GRID NO.	PART NO.	GRID NO.	PART NO.	GRID NO.	PART NO.	GRID NO.	PART NO.	GRID NO.	PART NO.	GRID NO.
127-W1412-00	B-5	395-14171-00	B-5	598-16321-01	B-11	3EE-21782-00	C-3	3EB-24110-01-W3	C-7	3E9-26111-10	C-13
257-W1541-01	B-9	637-14173-00	B-6	598-16324-00	B-11	3EE-21782-10	C-3	122-24181-00	C-7	353-26241-00	C-13
3FO-W2471-00	C-8	152-14174-00	B-6	257-16341-00	B-11	3EE-21782-20	C-3	3EE-24185-00	C-7	353-26242-00	C-13
2JL-W2536-01	C-5	260-14184-00	B-5	257-16342-00	B-11	136-22110-00-33	C-4	3EE-24240-01	C-7	1V1-26243-00	C-13
	C-11	470-14185-00	B-5	132-16346-00	B-9	180-22117-00	C-4	3EE-24240-11	C-7	1Y0-26290-10	C-13
3F1-11111-00	B-2	260-14190-12	B-5	257-16351-00	B-11	102-22123-00	C-4	3EE-24240-21	C-7	1X3-26311-00	C-13
517-11181-00	B-2	304-14261-00	B-6	137-16356-00	B-11	40X-22141-00	C-4	3EE-24500-04	C-7	394-26311-10	C-13
3EB-11311-00	B-2	5A3-14411-00	B-4	257-16357-00	B-11	296-22151-01	C-4	355-24518-01	C-7	3FO-26335-10	C-13
3AV-11351-00	B-2	3EB-14417-00	B-4	257-16371-01	B-11	3W3-22210-10	C-4	102-24522-01	C-7	355-26335-10	C-13
3EB-11400-00	B-3	3EB-14451-00	B-4	257-17121-00	B-12	3EE-22120-00	C-4	355-24523-00	C-7	1Y0-26341-00	C-13
3EB-11412-00	B-3	3EB-14453-00	B-4	257-17131-01	B-12	260-22311-00-35	C-4	603-24531-01	C-7	132-26341-10	C-13
3EB-11422-00	B-3	3EB-14473-00	B-4	257-17141-00	B-12	3AV-23101-10	C-6	122-24532-00	C-7	164-26363-00	C-13
260-11601-02	B-3	288-14481-02	B-4	257-17211-00	B-12	395-23111-00	C-6	122-24610-01	C-7	207-27111-00	C-14
260-11601-12	B-3	3EB-14498-00	B-4	257-17219-00	B-12	207-23112-00	C-6	122-24612-01	C-7	122-27112-00	C-14
260-11601-22	B-3	348-14611-00	B-7	257-17221-01	B-12	307-23114-00	C-6	3FO-24711-00	C-8	116-27114-00	C-14
3EB-11631-00-96	B-3	1L4-14612-00	B-7	257-17231-00	B-12	201-23116-00	C-6	214-24724-00	C-8	109-27115-00	C-14
102-11633-02	B-3	3M1-14613-00	B-7	3EB-17241-00	B-12	3W3-23117-00	C-6	3EB-24756-00	C-8	394-27211-00-91	C-14
3EB-11635-00	B-3	135-14710-00	B-7	257-17471-01	B-12	2R1-23121-00-33	C-6	3EB-24756-30	C-8	180-27231-01	C-14
3EB-11636-00	B-3	135-14713-00	B-7	3FO-17421-00	B-12	353-23122-91	C-6	3EB-24756-60	C-8	260-27411-00	C-14
3R1-11651-01	B-3	135-14714-00	B-7	257-17471-01	B-12	3E9-23124-00	C-6	3W3-24840-00	C-8	122-27413-00	C-14
257-11681-00	B-3	296-14753-02	B-7	257-18101-01	B-14	367-23125-60	C-6	1K8-25016-00-Y8	C-9	3FO-28100-00	B-15
1X5-13505-00	B-4	257-15111-02	B-8	257-18111-00-91	B-14	3W3-23126-00-35	C-6	109-25104-10	C-9	1X6-81310-20	C-15
378-13610-61	B-4	378-15121-60	B-8	132-18113-01	B-14	2R1-23131-00-33	C-6	517-25111-00-Y8	C-9	207-81312-21	C-15
314-13613-01	B-4	378-15359-60	B-8	132-18140-01	B-13	353-23132-91	C-6	195-25115-00	C-9	1X6-81313-20	C-15
314-13616-01	B-4	315-15362-01	B-9	259-18511-01	B-13	3E9-23134-00	C-6	322-25118-00	C-10	246-81321-20	C-15
3AV-13621-00	B-4	583-15371-00	B-8	257-18512-01	B-13	3W3-23136-00-35	C-6	296-25135-00	C-9	1X8-81325-20	C-15
3FO-14101-00	B-5	257-15413-00	B-9	257-18531-00	B-13	481-23141-01	C-6	109-25136-00	C-9	116-81331-20	C-15
126-14106-00	B-5	164-15415-00	B-9	257-18534-00	B-13	209-23142-40	C-6	102-25137-00	C-10	110-81345-21	C-15
283-14112-25	B-5	257-15417-01	B-11	257-18540-60	B-13	178-23145-00	C-6	296-25138-00	C-9	110-81346-21	C-15
405-14114-00	B-5	378-15421-60	B-9	136-18542-00	B-13	367-23146-60	C-6	183-25149-00	C-9		C-15
348-14116-03	B-5	257-15433-00	B-4	164-18561-00	B-13	178-23156-00	C-6	538-25155-00	C-9	1X6-81350-20	C-15
395-14121-00	B-5	3AV-15451-00	B-9	473-23110-03-33	B-15	207-23163-00	C-6	353-25181-03	C-11	353-81970-63	D-8
127-14125-01	B-6	3AV-15463-00	B-9	596-21158-00	B-15	3E9-23191-10	C-6	296-25304-10	C-11	1Y1-81975-00	D-8
127-14131-00	B-5	129-15489-10	B-9	3FO-21177-00	B-15	3E9-23191-20	C-6	463-25311-01-35	C-11	104-82110-29	D-8
127-14133-00	B-5	156-15618-01	B-10	596-21191-00	B-15	260-23318-40	C-6	109-25315-00	C-11	104-82122-00	D-8
156-14135-00	B-5	257-15620-01-91	B-10	135-21308-00	B-15	1Y2-23340-30-33	C-6	355-25321-10-35	C-11	1Y1-82131-00	D-8
287-14136-00	B-5	305-15641-00	B-10	3FO-21510-00	C-2	1M3-23346-00	C-6	3Y6-2533A-01	C-11	353-82150-00	D-8
127-14137-00	B-5	117-15644-00	B-10	122-21517-00	C-2	156-23411-00	C-6	3Y6-25351-00	C-11	116-82151-00	D-8
363-14137-00	B-5	257-15651-01	B-10	3AV-21610-00	C-2	183-23411-00	C-5		C-11	355-82310-40	D-8
353-14138-00	B-6	132-15653-00-10	B-10	526-21621-01	C-2	156-23412-00	C-5	1T9-25355-00	C-11	56J-82370-00	D-8
127-14141-14	B-5	305-15660-04	B-10	471-21623-00	C-2	183-23412-00	C-5	102-25371-00	C-11	3F6-82510-20	D-8
260-14142-25	B-5	132-15664-01	B-10	3EB-21711-00	C-3	136-23415-00	C-5	353-25381-00	C-12	205-82530-02	D-9
127-14143-22	B-5	257-15668-00	B-10	1Y1-21714-00	C-3	185-23435-00-98	C-5	1U0-25388-00	C-12	205-82538-00	D-9
127-14143-23	B-5	132-15676-01	B-10	3EB-21721-00	C-3	462-23441-00	C-5	102-25389-00	C-12	136-82540-00	D-9
127-14143-24	B-5	257-16111-01	B-11	1Y1-21724-00	C-3	462-23442-00-98	C-5	2A3-25412-00	C-11	3AV-82590-00	D-8
180-14158-01	B-5	257-16150-03	B-11	3EE-21781-00	C-3	134-23484-10	C-5	288-25445-10-33	C-11	3AV-82910-00	D-7
127-14161-00	B-5	122-16164-00	B-11	3EE-21781-10	C-3	3EB-24110-01-W1	C-7	1Y0-26111-00	C-13	3FO-82920-30	D-7
180-14168-00	B-5		B-11	3EE-21781-20	C-3	3EB-24110-01-W2	C-7	2L6-26111-20	C-13	3AV-83310-00	D-2

NUMERICAL INDEX

PART NO.	GRID NO.	PART NO.	GRID NO.	PART NO.	GRID NO.	PART NO.	GRID NO.	PART NO.	GRID NO.	PART NO.	GRID NO.
152-83311-10	D-2	34U-85110-00	D-9	90206-15021	B-10	90506-18288	C-9	92901-06200	B-2	93106-20001	C-9
	D-2	355-85111-01	D-9	90208-04029	C-5		C-11	92901-06600	B-4	93106-20002	C-11
	D-2	449-85131-02	D-6	90208-12015	B-11	90506-20041	C-14		C-2	93108-15001	B-11
	D-2	3F0-85132-00	C-2		B-11	90506-29054	C-14		C-2	93109-15001	B-10
34N-83312-00	D-2	90101-06278	C-9	90209-06095	D-6	90508-26136	B-10		C-13	93210-14104	C-10
	D-2		C-11	90209-10021	C-5	90508-32207	B-14		C-14	93220-08002	B-5
5Y1-83313-00	D-2	90101-08246	C-14	90249-12008	C-14	90560-10292	C-9	92901-08200	C-8	93306-20333	B-12
	D-2	90101-08538	B-15	90250-06013	B-13	90560-12170	C-11		C-12	93306-20458	B-3
	D-2	90101-10255	C-4	90267-40031	C-2	90560-17150	B-11	92901-08600	B-15	93306-30003	C-9
	D-2	90105-10006	C-5	90269-04003	C-5	91401-12010	B-5		D-5	93306-30101	C-11
3AV-83320-00	D-2	90109-06385	B-13	90280-03017	B-2	91401-16015	B-6	92901-10100	C-5	93306-30301	B-12
3AV-83330-00	D-2	90109-06343	B-4	90282-05005	B-11	91401-20015	C-12	92901-10200	C-4	93306-30302	B-3
34N-83332-00	D-2	90109-08183	C-11	90334-10006	B-8		C-14	92901-12100	C-15	93310-11268	B-3
	D-2	90109-08319	C-11	90338-07011	C-13	91401-20020	C-10	92906-08600	B-15	93310-41870	B-3
3AV-83340-00	D-2	90113-06009	B-11	90338-26136	B-8		C-12	92990-03100	B-4	93410-25017	B-10
38A-83350-10	D-9	90116-06026	B-2	90340-12005	B-8	91401-50085	C-3	92990-05100	C-8	93430-12008	C-14
474-83352-00	D-9	90119-05001	B-11	90387-06241	D-6	91609-40016	B-13		D-6	93440-16089	B-12
10V-83365-00	D-2	90119-06017	C-5	90387-06680	B-8	92501-06008	C-13	92990-05200	C-8		B-12
	D-2	90123-06011	C-13	90387-07390	D-6	92501-06012	B-12		D-6	93440-32017	B-13
2A7-83371-10	D-3	90149-05120	D-7	90387-10277	C-10		D-8		D-7	93450-13022	B-3
3F4-83510-F0	D-4	90149-08094	B-14	90387-12412	C-12		D-9		D-8	93501-04011	B-11
1M3-83513-00	D-4	90152-05005	D-5	90387-12760	C-12	92501-06014	B-4	92990-06100	B-15		C-5
122-83516-10	D-4	90157-05027	D-7	90387-17139	B-4		B-8		C-2	93503-16010	B-11
3F2-83519-00	D-4	90170-08158	C-11	90430-11034	D-9	92501-06030	B-8		C-2	93604-22050	B-13
4A7-83520-00	D-4	90170-10038	C-13	90430-12207	B-8		B-9		C-12	93605-20043	B-13
355-83522-00	D-4	90170-12060	B-11	90445-05013	B-6	92501-06040	B-6		D-8	93811-10001	B-12
355-83526-00	D-4	90170-12175	C-15	90445-05015	B-6		B-8		D-8		C-11
241-83550-01	D-4	90171-10004	C-10	90445-08171	D-8	92501-06050	B-8		D-8	94225-17082	C-9
137-83912-02-38	D-7		C-12	90445-09353	C-7		B-9		D-9		C-11
137-83931-01	D-7	90176-10013	C-4	90446-07009	B-8	92501-06055	B-8	92990-08100	B-8	94332-17112	C-11
2K3-83922-00	D-7	90179-06143	C-13	90462-06009	C-13	92501-06060	B-8		B-15		C-11
437-83936-00	D-7	90179-06176	C-14	90467-08003	C-7	92501-06065	B-8		B-15	94412-17002	C-9
232-83980-30	D-7	90179-12244	B-11	90468-10050	C-12	92503-06018	B-5		B-5	94414-17003	C-11
354-84111-00-33	D-5	90179-25051	C-5	90468-26048	B-10		B-9		C-2	94580-52098	C-11
468-84112-40	D-5	90185-10060	C-4	90480-01401	C-3		C-3		C-12	94680-52001	C-11
468-84120-40	D-5	90201-044A2	C-2	90480-10068	C-9	92503-06045	B-4		C-14	94701-00039	B-2
195-84315-01	D-5	90201-06059	D-6	90480-12012	B-9		B-8		D-5	95302-12600	D-2
195-84324-00	D-5	90201-061A5	C-12	90480-13015	C-2		B-9	92990-10600	C-5		D-2
2R9-84510-E0	D-6	90201-06412	D-4	90480-13203	B-15		B-6		C-10		D-3
1M8-84514-41	D-6	90201-07076	C-9	90480-14023	D-6	92701-06030	B-15	93102-04382	B-11	95303-05600	B-6
3AV-84517-10	D-6	90201-10437	C-4	90501-10245	C-14	92901-05100	B-7	93102-12106	B-14		B-7
543-84521-41	D-6		C-4	90501-20122	B-11		B-13	93102-17187	B-12		C-7
296-84523-00	D-6	90201-122A7	C-12	90506-06095	B-4		D-8	93102-20009	B-3		C-8
127-84524-30	D-6	90201-12535	C-15	90506-06106	B-4		B-8	93103-25078	B-8		D-6
2R9-84551-00-35	D-6	90201-12575	B-14	90506-07066	B-9	92901-05600	C-4	93104-07003	C-9		D-8
214-84553-01	D-6	90201-13202	B-10	90506-09009	B-14		C-4	93104-21016	C-11	95303-06600	B-2
2R9-84556-00	D-6	90201-20269	C-9	90506-09112	B-13		D-8	93105-47007	C-9		C-2

NUMERICAL INDEX

PART NO.	GRID NO.	PART NO.	GRID NO.	PART NO.	GRID NO.	PART NO.	GRID NO.	PART NO.	GRID NO.
95303-06600	C- 9	98501-05018	D- 7						
	C-11		D- 7						
	C-12	98501-05020	C- 4						
	D- 4	98501-05046	D- 7						
	D- 6	98503-05025	D- 8						
	D- 8	98511-04012	D- 2						
	D- 8		D- 2						
95303-06700	B-11		D- 2						
95303-06800	D- 6		D- 2						
95303-08600	B- 7	98580-04010	B- 4						
	B-14	98701-05016	C-15						
	B-15	99001-08600	B-13						
	B-15		B-13						
95303-08700	C-11	99001-10600	B-14						
	D- 5	99009-13400	B-10						
95303-10600	C- 5		B-12						
95601-05100	D- 7		B-12						
	D- 7	99009-15400	B-10						
95701-05500	D- 9	99009-16400	B-12						
95701-08500	B-15	99009-20400	C- 9						
95811-08090	B-15	99510-12016	B- 8						
95811-08120	B-15	99530-10014	B- 9						
95821-08100	B-15		B- 9						
97001-06020	D- 6								
	D- 6								
97001-08018	C- 8								
97001-08020	D- 5								
97001-08030	B-15								
97003-06012	B-15								
97011-06010	D- 9								
97011-06025	B-10								
97013-06012	D- 6								
97016-08016	B-15								
97021-06020	B-14								
97313-06016	C- 2								
97313-08012	C- 2								
97313-08016	B-15								
	C- 2								
97602-04125	C-15								
97702-40630	D- 2								
	D- 2								
	D- 2								
	D- 2								
98501-03008	B- 4								
98501-04006	B- 9								
98501-05008	C- 4								
98501-05012	B-13								
	D- 8								

COPY RIGHT: ALL RIGHTS RESERVE
NO PART OF THIS PUBLICATION MAY BE
REPRODUCED WITHOUT PERMISSION.



YAMAHA

YAMAHA MOTOR CO., LTD.
2500 SHINGAI IWATA-SHI SHIZUOKA-KEN JAPAN

PRINTED IN JAPAN
First edition Jan., 1990

T6